

Nylofor® Medium

1 General

1.1 Scope

The Nylofor® Medium Panels are produced by electrical resistance welded galvanized wires and subsequently PVC-coated in accordance with EN 10223-7.

The vertical wires have a barb at one side of the panel.

The panel is reinforced by means of 2 or more V-shapes in the horizontal direction of the panel see fig. 1.

The V-shapes are bent after PVC Coating.

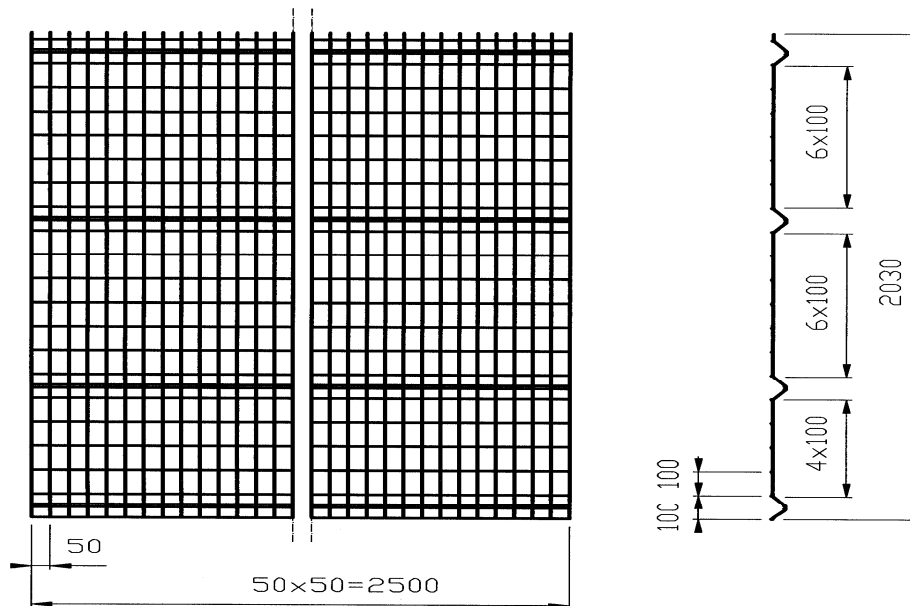

Figure 1 : Nylofor Medium panel, height 2030.

1.2 Normative references

- EN 10016-2: Non-alloy steel rod for drawing and/or cold rolling, Part 2: Specific requirements for general purposes rod.
- EN 10218-2: Steel wire and wire products – General, Part 2: Wire dimensions and tolerances.
- EN 10223-7: Steel wire and wire products for fences, Part 7: Steel wire welded panels for fencing.
- EN 10245-2: Steel wires and wire products / organic coatings on steel wire part 2: PVC finished wire

Nylofor® Medium

- Betafence drawing: see table 2.

1.3 Definitions

- Nominal wire diameter (d): the diameter in mm to designate the wire.
- Real wire diameter : the average value of the minimal and the maximal diameter , measured in the same section of a straight piece of wire, by means of a micrometer accurate to 0,01mm
- Mesh sizes : the distance measured between the centres of two neighbouring wires.

2 Raw Materials

2.1 Wire rod:

See table 1.

Element	%
C	≤ 0,10
Si	≤ 0,30
Mn	≤ 0,60
P	≤ 0,035
S	≤ 0,035

⁽¹⁾ In accordance with EN 10016-2 - C9D.

2.2 Zinc

Minimum 99,95 % of pure zinc.

2.3 PVC

The PVC is free of lead, cadmium and DOP.

Nylofor® Medium**3 Requirements****3.1 Wire diameter and tolerances**

- Core diameter of the horizontal galvanized wires: $3,80 \pm 0,06$ mm.
- Core diameter of the vertical galvanized wires: $3,30 \pm 0,05$ mm.
- Diameter of PVC-coated horizontal galvanised wires: $4,50 \pm 0,20$.mm
- Diameter of PVC-coated vertical galvanised wires: $4,00 \pm 0,20$.mm

The tolerances are in accordance with EN 10218-2.

3.2 Tensile strength of the wire

Vertical wires: 400 to 600 N/mm².

Horizontal wires: 400 to 600 N/mm².

3.3 Mesh sizes and tolerances

Mesh spacing is measured between the centres of two neighbouring wires:

- Distance between the horizontal wires : $100 \pm 3,0$ mm,
- Distance between the vertical wires : $50 \pm 3,0$ mm.

The tolerances are in accordance with EN 10223-7.

3.4 Welding strength

The average weld shear strength of 4 welds taken at random shall not be less than 50% of the breaking strength of the vertical wire (in accordance with EN 10223-7).

3.5 Overhang

The overhang of the horizontal wires shall be not more than 2 mm, burrs shall be avoided.

3.6 Panel**3.6.1 Dimensions of the panel**

Width : $2500 \pm 5,0$ mm, measured between the centres of the vertical wires

Height : see table 2 and fig. 2.; tolerance $\pm 5,0$ mm. (measured centre – centre)

Nylofor® Medium

Table 2: Dimensions of the panel

Overall height of the panel mm	Number of horizontal wires	Number of V-shapes	Betafence drawing
1030	15	2	NYL50P002002
1230	17	2	NYL50P002003
1530	22	3	NYL50P002004
1730	24	3	NYL50P002005
1930	26	3	NYL50P002006
2030	29	4	NYL50P002007

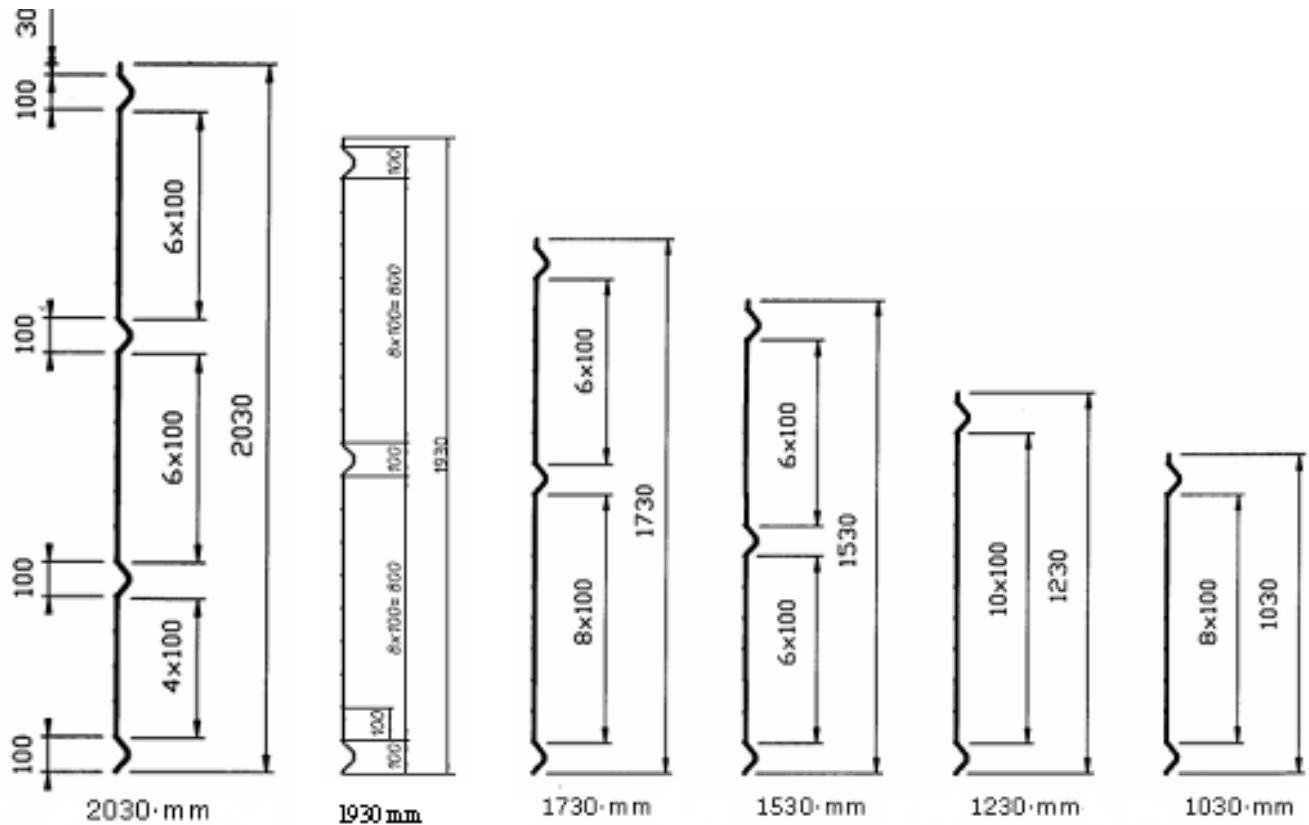

Figure 2

Nylofor® Medium**3.6.2 V-shapes in the vertical wires**

Number of V-shapes: see table 2.

Dimension of the V-shapes: see fig. 3.

- spacing between the horizontal wires : $100 \pm 2,0$ mm,
- depth : $36 \pm 2,0$ mm (see fig. 3)

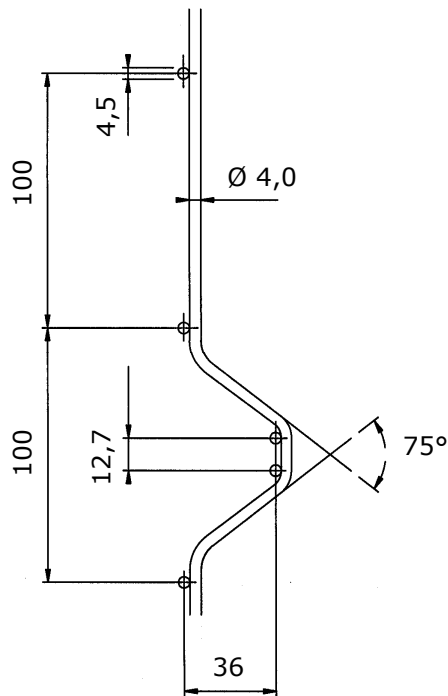

Figure 3

3.6.3 Barbs

The vertical wires have, at one side of the panel, a barb of 30 ± 2 mm measured from the underside of the upper horizontal wire

Nylofor® Medium

3.7 Coating

3.7.1 Metallic coating

The wires are galvanized and the min. zinc weight for the horizontal and vertical wires is 30 g/m².

3.7.2 PVC coating

The panels are after welding subsequently PVC coated and the layer has a minimum thickness of 200µm.

Colour: Green RAL 6005 or white RAL 9010.

The PVC coating is fused and adhered to a primer that is cured onto the galvanized core wire, thus achieving an excellent bond between wire and PVC (in accordance with EN 10245 part2 class 2b).

4 Form of delivery

Number of panels per pallet, weight and sizes: see table 3.

Panels are delivered on a four-way pallet.

Four wooden beams are used to give more stability to the pallet and to avoid gliding of the panels.

Panels are strapped and packed in water resistant foil to protect against damages.

A label is stuck on each side of the pallet stating SAP-code, mesh size, width, height and numbers of panels put on the pallet.

Table 3: Form of delivery and packing			
Nominal dimensions of the panel cm	Number of panels per pallet	Weight of the panel kg	Sizes of the forwarding unit L x W x H cm
250 x 103	50	7,5	252 x 110 x 55
250 x 123	50	8,7	252 x 130 x 55
250 x 153	50	11,1	252 x 160 x 55
250 x 173	50	12,3	252 x 180 x 55
250 x 193	50	13,5	252 x 200 x 55
250 x 203	50	14,7	252 x 210 x 55